

PLAN
3/8" = 1'-0"

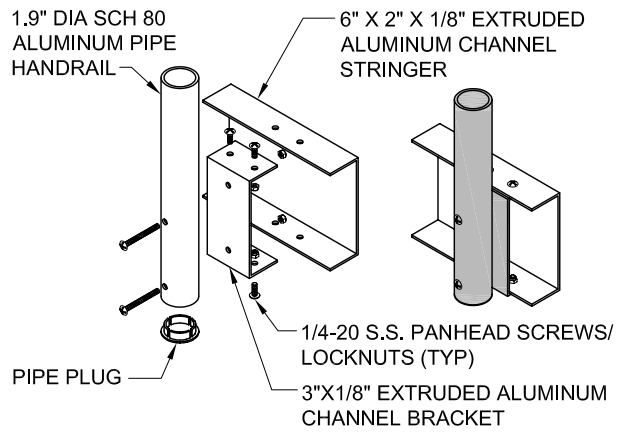

HANDRAIL BRACKET
NTS

1.9" DIA SCH 80 PIPE HANDRAIL BOLTED TO MOUNTING CHANNEL W/ (2) 1/4-20 X 2-1/2" S.S. PANHEAD SCREWS/ LOCKNUTS

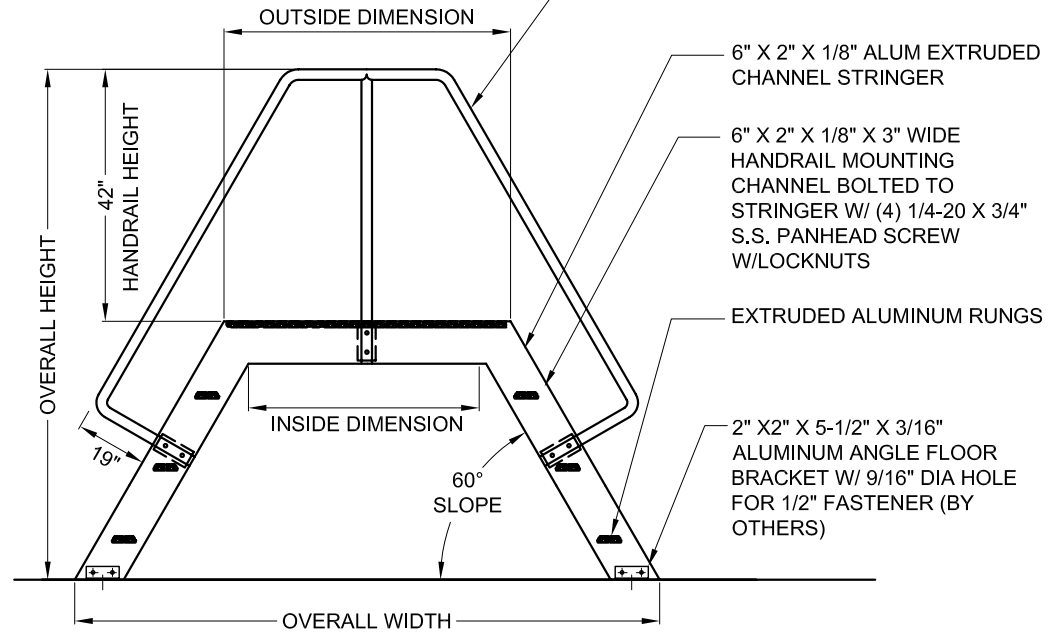

SIDE ELEVATION
3/8" = 1'-0"