

APEX
1/2" x 1'-0"

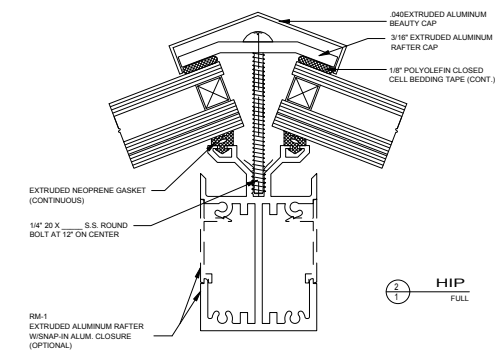

HIP
FULL

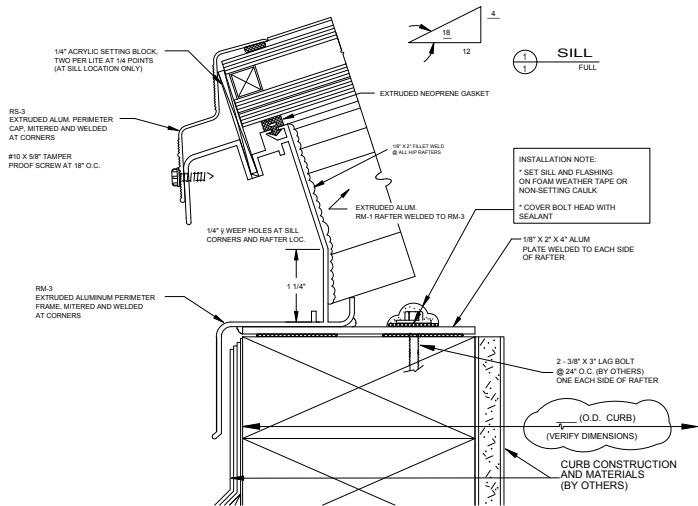

INSTALLATION NOTE:
 * SET SILL AND FLASHING ON FOAM WEATHER TAPE OR NON-SETTING CAULK
 * COVER BOLT HEAD WITH SEALANT

OCTAGON SKYLIGHT

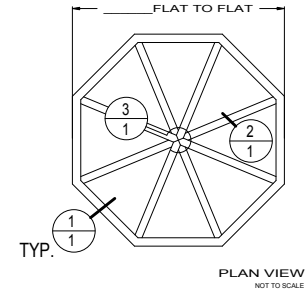
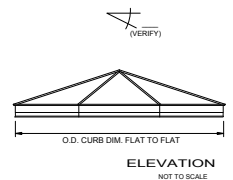

SKYLIGHT SCHEDULE

UNIT	QTY.	TYPE	SLOPE	O.D. CURB DIM. (W X H)	LOCATION	# LITES	GLAZING:
		OCTAGON	4:12			8	FINISH:
							COLOR:
							INSTALLATION:
							FIELD GLAZED <input type="checkbox"/> SHOP GLAZED <input type="checkbox"/>

Royalite
 1055 TERMINAL WAY
 SAN CARLOS, CA 94070
 PHONE: (650) 637-1440
 FAX: (650) 637-8770

JOB No.:	PROJECT NAME:	SHEET No.:
DRAWN BY: MIDPOINT	CONTRACTOR:	1 of 1
DATE:	PHONE:	REVISED DATE: